

- **NR3633RSV** 35-3/4"L x 33"D x 32-7/8"H
- **NR4833RSV** 47-3/4"L x 33"D x 32-7/8"H
- **NR6033RSV** 59-3/4"L x 33"D x 32-7/8"H
- **NR7233RSV** 71-3/4"L x 33"D x 32-7/8"H

Included

- NOTE: Glass warranty only applicable to first point of delivery
- Breeze~E (Type-II) w/ EnergyWise s/c refrigeration
- Blue Fin coated coil
- Compressor air intake from rear and out front panel at toe kick. Front panel cannot be blocked.
- Condensate pan (self-contained refig. only)
- Integrated average product temperature of 40°F or less
- LED top light
- One piece formed ABS plastic tub
- One year parts & labor; 5 year compressor warranty
- Vertical, fixed front & side UV bonded frameless glass



NR4833RSV

Specify	Standard Features	Additional Options
FRAME EXTERIOR COLOR	• Black	• Painted (non-stock colors, specify RAL#) • Painted (stock colors, specify RAL#) • Stainless steel
INTERIOR COLOR	• Black	• NOTE: Interior color must be FDA & NSF approved • Painted (stock colors, specify RAL#) • Stainless steel
PANEL EXTERIOR	• Laminated (non-premium) Confirm pattern/grain direction	• Laminated (premium) Confirm pattern/grain direction • Stainless steel
BASE SUPPORT	• Adjustable, locking casters	• 6"H stainless steel legs • Shims (standard w/ remote)
END PANEL LEFT	• Full end panel	• No end panel w/ synchronized defrost
END PANEL RIGHT	• Full end panel	• No end panel w/ synchronized defrost
LOWER FRONT PANEL	• Black	• Painted (stock colors, specify RAL#) • Stainless steel
LOWER REAR PANEL	• Black	• Painted (stock colors, specify RAL#) • Stainless steel
UPPER REAR	• Clear glass rear sliding doors	• Reflective glass rear sliding doors
LIGHTS	• LED 3500K w/ frosted lens	• LED 3000K w/ frosted lens • LED 4000K w/ frosted lens
ELECTRICAL CONNECT	• 10' Straight blade power cord (self-cont.)	• 10' Locking power cord (self-cont.) • Electrical leads (remote)
REFRIGERATION	• Breeze~E (Type-II) w/ EnergyWise s/c refrigeration (rear access)	• Breeze~E (Type-II) w/ EnergyWise s/c refrigeration (front access) • Remote w/thermostat, solenoid & TXV (front access) • Remote w/thermostat, solenoid & TXV (rear access)
MISCELLANEOUS		1 • 14.5" Base height extension • Rear door lock • Second year parts & labor warranty (excludes compressor)
ACCESSORIES		• Clean Sweep® coil cleaner (n/a w/remote)

Option Notes: 1 - Cannot be combined w/ 6"H legs

Intended Environment: Type II - Designed to operate in ambient conditions of 80°F and 60% relative humidity unless noted otherwise in system information below.		
Zone	Intended Product To Be Displayed	Warmest Avg Prod Temp ° F
1	Unpackaged refrigerated products	40

PLAN VIEW

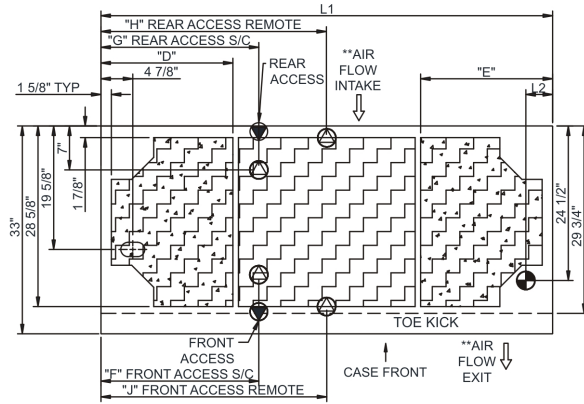

	"D"	"E"	"F"	"G"	"H"	"J"
NR3633RSV	N/A	N/A	7"	7"	17 7/8"	17 7/8"
NR4833RSV	9"	9"	12 3/4"	12 3/4"	23 7/8"	23 7/8"
NR6033RSV	9"	21"	12 3/4"	24 3/4"	29 7/8"	29 7/8"
NR7233RSV	21"	21"	25 1/8"	25 1/8"	35 7/8"	35 7/8"

SIDE VIEW

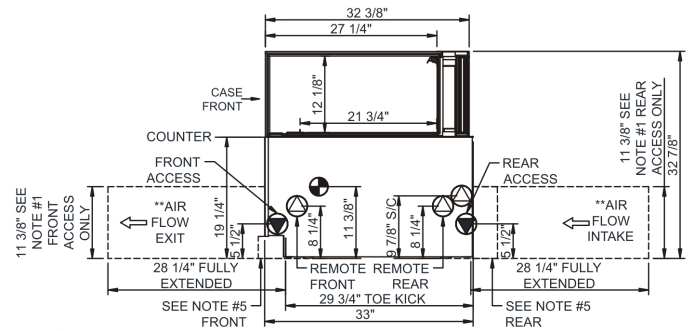

- NOTES:**
- 11 3/8" TALL, FULL WIDTH OF CASE OPENING IN CABINET OR COUNTER IS REQUIRED TO PULL OUT REFRIGERATION SYSTEM.
 - BACK OF COUNTER / CABINET MUST BE VENTED PROPERLY FOR ADEQUATE AIRFLOW TO CONDENSER.
 - **REPRESENTS REAR PULLOUT REFRIGERATION. AIR FLOW INTAKE AND EXIT DETAILS ARE REVERSED WITH FRONT PULLOUT REFRIGERATION OPTION.
 - SELF-CONTAINED ACCESS ONLY BY PULLING OUT CONDENSER UNIT.
 - 4" OPEN AREA CLEARANCE REQUIRED FOR AIR FLOW FRONT AND REAR OF CASE.

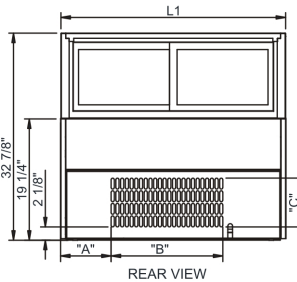

	"A"	"B"	"C"
NR3633RSV	8"	17 3/4"	7 3/4"
NR4833RSV	14"	17 3/4"	7 3/4"
NR6033RSV	26"	17 3/4"	7 3/4"
NR7233RSV	26"	17 3/4"	7 3/4"

NOTE: ALL DIMENSIONS APPROXIMATE

- ELECTRICAL JUNCTION BOX (SUPPLIED WITH 6" LEADS OR POWER CORD).
- LOCATION OF DRAIN TUBE FOR REMOTE REF. ONLY (SUPPLIED WITH 3/4" OR 1 1/2" PVC TUBE).

- REFRIGERATION LINE CONNECTION.
- REMOTE FLOOR SINK & UTILITIES ACCESS AREA.

- SELF-CONTAINED CASE SERVICE ACCESS AREA.
- DRY CASE SERVICE ACCESS AREA.

Model Technical Specifications																
Model	L"	L1"	L2"	System Circuit Volts		Phs	Freq	Amps ***	Watts	Wires	NEMA Plug	SST	Conv. Rack RTUH	Para. Rack RTUH	Est Wt	
NR3633RSV	N/A	35.75	4.13	Remote(Type I)	Circuit #1	110-120	1	60	0.78	14	2+G	Leads Single	20.00	626	580	600
				Remote(Type II)	Circuit #1	110-120	1	60	0.78	14	2+G	Leads Single	20.00	713	660	
				Self-Contained (R513A)	Circuit #1	110-120	1	60	9.46	744	2+G	5-15P or L5-15P	N/A	N/A	N/A	
NR4833RSV	N/A	47.75	4.13	Remote(Type I)	Circuit #1	110-120	1	60	1.08	30	2+G	Leads Single	20.00	821	760	750
				Remote(Type II)	Circuit #1	110-120	1	60	1.08	30	2+G	Leads Single	20.00	929	860	
				Self-Contained (R513A)	Circuit #1	110-120	1	60	9.76	759	2+G	5-15P or L5-15P	N/A	N/A	N/A	
NR6033RSV	N/A	59.75	4.13	Remote(Type I)	Circuit #1	110-120	1	60	1.38	45	2+G	Leads Single	20.00	1015	940	850
				Remote(Type II)	Circuit #1	110-120	1	60	1.38	45	2+G	Leads Single	20.00	1145	1060	
				Self-Contained (R513A)	Circuit #1	110-120	1	60	10.06	775	2+G	5-15P or L5-15P	N/A	N/A	N/A	
NR7233RSV	N/A	71.75	4.13	Remote(Type I)	Circuit #1	110-120	1	60	1.38	47	2+G	Leads Single	20.00	1210	1120	950
				Remote(Type II)	Circuit #1	110-120	1	60	1.38	47	2+G	Leads Single	20.00	1361	1260	
				Self-Contained (R513A)	Circuit #1	110-120	1	60	10.06	777	2+G	5-15P or L5-15P	N/A	N/A	N/A	

*** Does not include electric defrost on freezer models.

Regulatory Approvals:

All Models	Accordance with AHRI Std 1200 ETL Listed to UL 471 ETL Listed to CAN/CSA 22.2 No. 120 ETL Sanitation to NSF/ANSI 7
------------	---



In Accordance with
AHRI Std 1200

DOE 2017
Energy Efficiency
Compliant

Important Notes:

- 1) ELECTRICAL NOTE: If GFCI is required, a GFCI breaker MUST be used in lieu of a GFCI receptacle
- 2) Back side of counter must be open or vented the full length of the unit to allow proper ventilation for the refrigeration system.
- 3) Glass warranty only applicable to first point of delivery.

⚠ WARNING: This product can expose you to chemicals, including Urethane (Ethyl Carbamate), which are known to the State of California to cause cancer and birth defects or other reproductive harm. For more information go to www.P65Warnings.ca.gov.